



4675 West 160th St
 Cleveland, OH 44135
 PH: 1.800.321.9532
 FX: 1.800.321.9535

ENGINEERING SUBMITTAL

INSERT DRAINS WITH DOME

Job Reference

Engineering Specification: Arfco Insert Drains are designed for quick and easy retro-fit in drain openings for re-roofing applications. Insert Drains consist of a molded ultraviolet stabilized polyethylene or cast aluminum dome strainer, a cast aluminum epoxy coated gravel guard and clamping ring, 14" O.D. injection molded ultraviolet stabilized black ABS drain flange with top rib flashing lock. The outlet pipe has a pre-compressed modified asphalt impregnated expanding foam, sealing tape, having a temperature range of -40 F to +185 F and 150% minimum elongation.

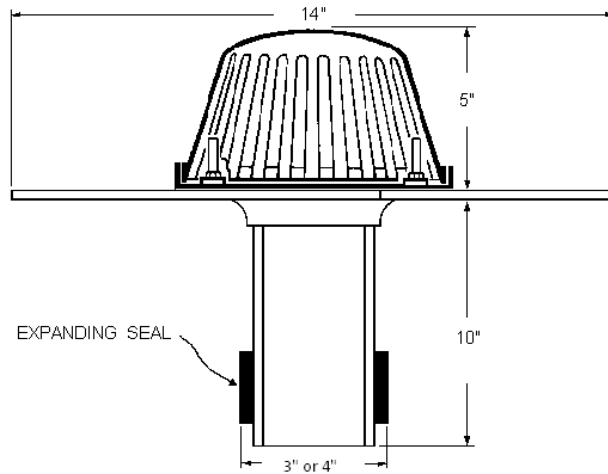

- ◆ Insert drains are designed to sleeve into the existing drain pipe below the existing roof drain
- ◆ Flush mounting drain has self-expanding modified asphalt seal activated immediately before installation by removing restraining tape
- ◆ Insert drains are manufactured with flat flange for flush mounting to prevent damming of water
- ◆ Dome strainers bolt down to securely prevent vandalism.
- ◆ Insert drains are completely installed from the rooftop with no special tools and require only one- 7/16" wrench to secure the clamping rings and domes

✓	Product No.	Description	Pack	Carton Weight
	14671	3" ABS Drain with Plastic Dome	1	4
	14672	4" ABS Drain with Plastic Dome	1	4
	14680	3" ABS Drain with Cast Aluminum Dome	1	9

Data is subject to manufacturing tolerances.